

# The High Performance Touch Panel PC

Highly reliability and flexible touch Panel PC with Intel Sandy Bridge Quad/ Dual Core CPU empower high technique operation application

**X-PPC 950**



Support Intel® Sandy Bridge  
Quad / Dual Core CPU



Front Panel IP 65 Compliance



Support Dual LAN ,  
2 Removable Hard Disk Drive Bay  
and Hard Disk RAID Function



Support Pole / Arm mountable  
with VESA standard

## Specifications

<b>Model Name</b>	X-PPC 950
<b>Main Board</b>	2nd Generation Intel® Core Processor (Sandy Bridge LGA1155) Core i7 - 2600 3.4 GHz / 4 core / 95 watt Core i5 - 2400 3.1 GHz / 4 core / 95 watt Core i3 - 2120 3.3 GHz / 2 core / 65 watt Intel® Pentium® G850 2.9GHz / 2 core / 65 watt Intel® Celeron® G540 2.5GHz / 2 core / 65 watt
	Core Logic Intel® Q67
	System Memory DIMMx2, DDR3 1333 max. up to 8GB per channel
	OS Support Windows® XP / WES, POSReady 2009, Windows 7
	TFT LCD Size 15"
<b>Display</b>	Brightness 250 nits, brightness adjustment by BIOS
	Resolution 1024 x 768
	Touch Screen 5 wire resistive type
<b>Storage Device</b>	HDD 2 x 2.5" Removable HDD Drive Bay , RAID function
	CFast 1 x slot CFast
<b>I/O Ports</b>	Serial 5 x RS-232 COM 1 : RS-232/422/485, DB-9, Pin9 w/ RI/5V/12V Selectable by BIOS COM 2 / 5 : DB-9, Pin9 w/ RI/5V/12V Selectable by BIOS COM 3 : RS232, internal pin header for MSR COM 6 : RS232, internal pin header for Customer Display
	Parallel 1 x DB25
	USB 6 x USB 2.0
	PS/2 Keyboard / Mouse 1 x Mini-DIN
	LAN 2 x Gigabit Ethernet by RJ-45 , Support Wake on LAN
	Cash Drawer 1 x RJ11 (24VDC)
	Audio MIC-in , Line-in , Line out
	VGA 1 x DB15
	Wall mount Support VESA Mount
	Power Input External adapter,180Watt, 19VDC input
<b>Others</b>	Color Black
	Material Plastic / Aluminum
	EMC& Safety Compliance FCC / CE / WEEE / RoHS / VCCI
	Front Panel Protection IP 65 compliance
	Weight 5.88 Kgs
	Dimension 380W x 88D x 292H (mm)
	Operating Temperature 0°C ~ 40°C
	Storage Temperature -20°C ~ 60°C
	Humidity 20% - 90% RH, non-condensing

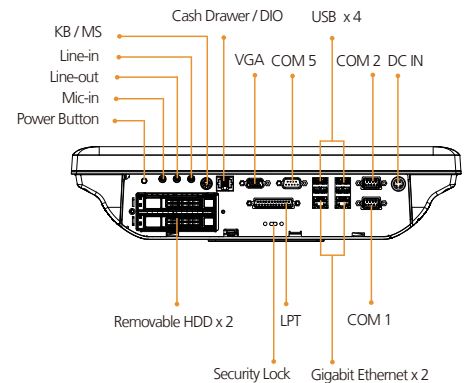
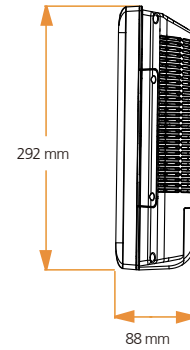
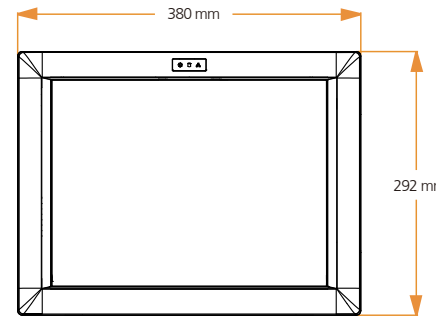

## Ordering information

### Main Unit

Part No.	Description
XPPC90-5B-i7	Touch Panel PC w/ 15" TFT LCD, Intel® Sandy Bridge LGA1155 , Core i7 - 2600 3.4 GHz / 4 core / 95 watt
XPPC90-5B-i5	Touch Panel PC w/ 15" TFT LCD, Intel® Sandy Bridge LGA1155 , Core i5 - 2400 3.1 GHz / 4 core / 95 watt
XPPC90-5B-i3	Touch Panel PC w/ 15" TFT LCD, Intel® Sandy Bridge LGA1155 , Core i3 - 2120 3.3 GHz / 2 core / 65 watt
XPPC90-5B-P	Touch Panel PC w/ 15" TFT LCD, Intel® Pentium® G850 2.9GHz / 2 core / 65 watt
XPPC90-5B-C	Touch Panel PC w/ 15" TFT LCD, Intel® Pentium® G540 2.5GHz / 2 core / 65 watt

Part No.	Description
20900025	OS License: Windows 7 Professional for Embedded Systems, English Version
20300030	Memory: DDR3, 1GB, 240PIN
20300031	Memory: DDR3, 2GB, 240PIN
20300032	Memory: DDR3, 4GB, 240PIN
20300033	Memory: DDR3, 8GB, 240PIN
A0400807	Wireless LAN: IEEE 802.11 B/G, USB Type
20200028	2.5" Slim Type HD: 160GB SATA Type

Specifications are subject to change without notice. Issue Date: 2011 / 10

### Optional Accessories

Part No.	Description
Z0500002	MSR-Front Type, 3 Tracks, PS/2 Type
Z0500004	MSR-Side Type, 3 Tracks, PS/2 Type & Finger Print, USB Type
Z0500005	MSR-Side Type, 3 Tracks, PS/2 Type & i-Button, PS/2 Type
Z0500006	MSR-Side Type, 3 Tracks, PS/2 Type & RFID, USB Type
Z0600039	CFast Card : 2GB
Z0600040	CFast Card : 4GB
Z0600041	CFast Card : 8GB
Z0600042	CFast Card : 16GB
20900001	OS License: Windows XP Professional for Embedded Systems, English Version
20900023	OS License: Windows Embedded Standard, English Version
20900021	OS License: Windows Embedded POSReady 2009, English Version

# EBN

EBN Technology Corp.

## EBN Technology Corp.

10F, No.90, Sec.1, Xintai 5th Rd., Xizhi Dist.,  
New Taipei City 221, Taiwan (R.O.C.)

TEL : +886-2-2696 9292

FAX : +886-2-2696 9393

E-mail : sales@ebn-pos.com

www.ebn-pos.com